

XS-82H XS-83H XS-84H

MULTI-FORMAT MATRIX SWITCHER

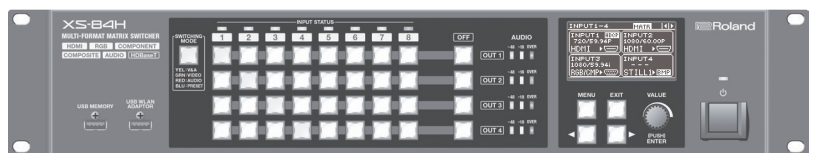
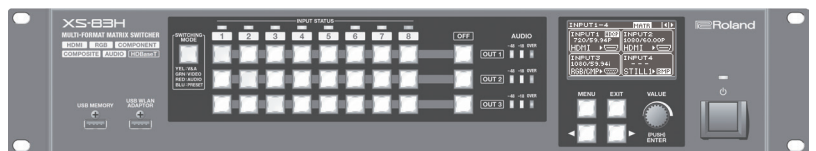
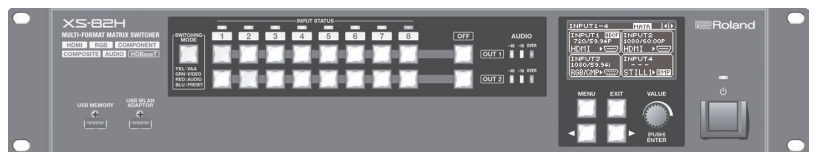

Reference Manual

Version 2.00 and later

Before using the XS-82H/XS-83H/XS-84H, ensure that its system program is at the most recent version. For information on available upgrades for the system program, see the Roland website (<http://proav.roland.com>).

You can check the version of the system program by selecting the [MENU] button → "SYSTEM" → "VERSION."

Contents

| | |
|--|----------|
| Menu List | 3 |
| VIDEO INPUT | 3 |
| VIDEO OUTPUT | 4 |
| TRANSITION | 5 |
| OFF SWITCH | 5 |
| MULTI | 6 |
| AUDIO INPUT | 6 |
| AUDIO OUTPUT | 8 |
| AUDIO CONTROL | 9 |
| MODE | 9 |
| PRESET MEMORY | 9 |
| EDID | 10 |
| Data Sent When Set to "INTERNAL" | 10 |
| RS-232C | 11 |
| LAN | 11 |
| WIRELESS LAN | 11 |
| USB MEMORY | 11 |
| SYSTEM | 12 |

| | |
|---|-----------|
| Network Settings | 13 |
| Network Functions | 13 |
| Connecting via Wi-Fi | 14 |
| Preparations | 14 |
| Checking the Wi-Fi Connection Status | 14 |
| Directly Connecting the Unit and the iPad (Ad-hoc Mode)... .. | 14 |
| Connecting to a Wi-Fi Router by WPS | 15 |
| Selecting and Connecting to a Wi-Fi Router | 15 |
| Setting the Wireless ID | 16 |
| Checking the Wi-Fi Information | 16 |
| Making a Wired Connection to the Wi-Fi Router | 16 |

| | |
|---|-----------|
| Important Notes When Working with Copyright-protected (HDCP) Video | 17 |
|---|-----------|

| | |
|--|-----------|
| Command Reference | 18 |
| Specification of the RS-232C Connector | 18 |
| Overview of Commands | 18 |
| Control Using the LAN Port | 18 |
| Received Commands | 19 |
| Sent Commands | 21 |

* Roland is an either registered trademark or trademark of Roland Corporation in the United States and/or other countries.

* Company names and product names appearing in this document are registered trademarks or trademarks of their respective owners.

Menu List

Pressing the [MENU] button displays the menu.

MEMO

- The default value is printed in bold characters.
- You can return the menu item you're setting to its factory-default value by holding down the [VALUE] dial and pressing the [EXIT] button.
- You can change the setting value in larger steps by holding down the [VALUE] dial as you turn it.

VIDEO INPUT

* The ranges of settings vary according to input/output format. Also, some changes to setting values do not alter the video picture.

| Menu item | | Value | Description |
|--------------|-------------------------|--|---|
| 2nd level | 3rd level | | |
| INPUT-1 : | INPUT SELECT | HDMI , RGB/COMPONENT, COMPOSITE, YC, STILL1, STILL2, STILL3, STILL4, SHARE (*1) | This sets the type of video signal to input. |
| INPUT-8 | HDCP INPUT ENABLE (*2) | DISABLE, ENABLE | This sets whether input of copyright-protected (HDCP) video is permitted (p. 17). |
| | AUTO SAMPLING (*3) (*4) | (ENTER) | This executes automatic adjustment during RGB signal input. |
| | COLOR SPACE (*5) | AUTO , RGB (0-255), RGB (16-235), YCC (SD), YCC (HD) | This sets the color space for input video. |
| | FLICKER FILTER (*5) | OFF , ON | Setting this to "ON" reduces flicker in input video. |
| | ZOOM (*6) | 10 %– 100 % –1000 % | This adjusts the zoom ratio of input video. |
| | TYPE | FULL , LETTERBOX, CROP, DOT BY DOT, MANUAL | This adjusts the aspect ratio of input video. |
| | MANUAL SIZE H | -2000– 0 –2000 (pixel) | This adjusts the horizontal size of input video. |
| | MANUAL SIZE V | -2000– 0 –2000 (pixel) | This adjusts the vertical size of input video. |
| | POSITION H | -1920– 0 –1920 (pixel) | This adjusts the horizontal position of input video. |
| | POSITION V | -1200– 0 –1200 (pixel) | This adjusts the vertical position of input video. |
| | FLIP VERTICAL (*7) | OFF , ON | Setting this to "ON" flips input video vertically. |
| | BRIGHTNESS | -64– 0 –63 | This adjusts the brightness of input video. |
| | CONTRAST | -64– 0 –63 | This adjusts the contrast of input video. |
| | SATURATION | -64– 0 –63 | This adjusts the color saturation of input video. |
| | RED | -64– 0 –63 | This adjusts the red level of input video. |
| | GREEN | -64– 0 –63 | This adjusts the green level of input video. |
| | BLUE | -64– 0 –63 | This adjusts the blue level of input video. |
| | FREQUENCY (*3) | -128– 0 –127 | This adjusts the frequency. |
| | PHASE (*3) | -128– 0 –127 | This adjusts the phase. |

(*1): "SHARE" can be set using INPUT-2 through 8. This enables sharing of the video source on the channel previous to the set channel. For details, refer to the Owner's Manual, "Sharing a Video Source (SHARE)" (p. 19).

(*2): This can be set only when "INPUT SELECT" is set to "HDMI."

(*3): This can be set only when "INPUT SELECT" is set to "HDMI" or "RGB/COMPONENT."

(*4): This can be executed only when the corresponding video input channel has been selected with cross point.

(*5): This can be set only when "INPUT SELECT" is set to "RGB/COMPONENT."

(*6): When the settings described below are in effect, reducing to smaller than the input size is not possible.

- When the "MODE" setting is a value from "ROTATION-L1" to "ROTATION-L4" or from "ROTATION-R1" to "ROTATION-R4"
- When "INPUT SELECT" is set to a value from "STILL1" to "STILL4"

(*7): Vertical flipping is not possible when "INPUT SELECT" is set to a value from "STILL1" to "STILL4."

VIDEO OUTPUT

* The ranges of settings vary according to input/output format. Also, some changes to setting values do not alter the video picture.

| Menu item | | Value | Description |
|---|----------------------------|--|--|
| 2nd level | 3rd level | | |
| OUTPUT-1 | OUTPUT SELECT | AUTO, HDMI, HDBaseT | This sets the OUTPUT connector for video output. |
| OUTPUT-4 * This varies according to model. | RESOLUTION (*8) (*9) | <ul style="list-style-type: none"> When "FRAME RATE" under "SYSTEM" is set to "59.94 Hz" 480i 4: 3, 480i 16: 9, 480p 4: 3, 480p 16: 9, 720/59.94p, 1080/59.94i, 1080/59.94p, 640 x 480/60, 800 x 600/60, 1024 x 768/60, 1280 x 768/60, 1366 x 768/60, 1280 x 1024/60, 1400 x 1050/60, 1600 x 1200/60, 1920 x 1200/60 When "FRAME RATE" under "SYSTEM" is set to "50 Hz" 576i 4: 3, 576i 16: 9, 576p 4: 3, 576p 16: 9, 720/50p, 1080/50i, 1080/50p, 640 x 480/75, 800 x 600/75, 1024 x 768/75, 1280 x 768/75, 1366 x 768/75, 1280 x 1024/75, 1400 x 1050/75, 1600 x 1200/60, 1920 x 1200/60 | This sets the output resolution. |
| | HDCP OUTPUT ENABLE | DISABLE, ENABLE | This sets whether output of copyright-protected (HDCP) video is permitted (p. 17). |
| | COLOR SPACE | AUTO, RGB (0-255), RGB (16-235), YCC (444), YCC (422) | This sets the color space of output video. |
| | DVI-D/HDMI SIGNAL | DVI-D, HDMI | This sets the type of video signal to output from the OUTPUT connectors. |
| | FLIP HORIZONTAL | OFF, ON | Setting this to "ON" flips input video horizontally. |
| | ZOOM (*8) (*10) | 10 %–100 %–1000 % | This adjusts the zoom ratio of output video. |
| | MANUAL SIZE H (*8) | -4096–0–4096 (pixel) | This adjusts the horizontal size of output video. |
| | MANUAL SIZE V (*8) | -1920–0–1920 (pixel) | This adjusts the vertical size of output video. |
| | POSITION H (*8) | -4096–0–4096 (pixel) | This adjusts the horizontal position of output video. |
| | POSITION V (*8) | -1200–0–1200 (pixel) | This adjusts the vertical position of output video. |
| | CROPPING ORIENT (*8) | UPPER LEFT, UPPER RIGHT, LOWER LEFT, LOWER RIGHT, CENTER | This sets the reference point for cropping. |
| | CROPPING TYPE (*8) | FULL, 4: 3, 5: 4, 16: 9, MANUAL | This sets the type of cropping. |
| | CROPPING SIZE H (*8) (*11) | 10–128–2000 (pixel) | This adjusts the horizontal cropping width. |
| | CROPPING SIZE V (*8) (*11) | 10–128–2000 (pixel) | This adjusts the vertical cropping width. |
| | BRIGHTNESS | -128–0–127 | This adjusts the brightness of output video. |
| | CONTRAST | -128–0–127 | This adjusts the contrast of output video. |
| | SATURATION | -128–0–127 | This adjusts the color saturation of output video. |
| | RED | -128–0–127 | This adjusts the red level of output video. |
| | GREEN | -128–0–127 | This adjusts the green level of output video. |
| | BLUE | -128–0–127 | This adjusts the blue level of output video. |

(*8): When the "MODE" setting is as shown below, the settings for OUTPUT-2 through OUTPUT-4 are shared with the OUTPUT-1 setting. They cannot be changed individually.

| MODE | OUTPUT-2 | OUTPUT-3 | OUTPUT-4 |
|---------|------------------------------|------------------------------|------------------------------|
| MULTI-2 | Shared with OUTPUT-1 setting | Can be set independently | Can be set independently |
| MULTI-3 | Shared with OUTPUT-1 setting | Shared with OUTPUT-1 setting | Can be set independently |
| MULTI-4 | Shared with OUTPUT-1 setting | Shared with OUTPUT-1 setting | Shared with OUTPUT-1 setting |

(*9): When the "MODE" setting is as shown below, the settings for OUTPUT-2 through OUTPUT-4 are shared with the OUTPUT-1 setting. They cannot be changed individually.

| MODE | OUTPUT-2 | OUTPUT-3 | OUTPUT-4 |
|--|------------------------------|------------------------------|------------------------------|
| SPAN-2 | Shared with OUTPUT-1 setting | Can be set independently | Can be set independently |
| SPAN-3 | Shared with OUTPUT-1 setting | Shared with OUTPUT-1 setting | Can be set independently |
| SPAN-4, ROTATION-L1–4, ROTATION-R1–4, 4K-1, 4K-2 | Shared with OUTPUT-1 setting | Shared with OUTPUT-1 setting | Shared with OUTPUT-1 setting |

(*10): When the settings described below are in effect, reducing to smaller than the input size is not possible.

- When the "MODE" setting is a value from "ROTATION-L1" to "ROTATION-L4" or from "ROTATION-R1" to "ROTATION-R4"
- When the "INPUT SELECT" setting under "VIDEO INPUT" is a value from "STILL1" to "STILL4"

(*11): Effective when "CROPPING TYPE" under "OUTPUT VIDEO" is set to "MANUAL."

VIDEO OUTPUT (continued)

| Menu item | | Value | Description |
|--|---------------------------|---|--|
| 2nd level | 3rd level | | |
| OUTPUT-1 : OUTPUT-4 * This varies according to model. | GUIDE COLOR (*12) | OFF , WHITE, YELLOW, CYAN, GREEN, MAZENDA, RED, BLUE | This switches between displaying the guide (in the selected color) and hiding the guide. When a color is selected, a guide showing the effective range for video is displayed on the output screen. The interior of the guide is the effective range. |
| | GUIDE SIZE (*12) | 10- 90 -100 | This sets the guide's size. |
| | GUIDE WIDTH (*12) | 1- 2 -100 | This sets the thickness of the guide's border lines. |
| | OUTPUT1 SYNC (*13) | OFF , ON | Setting this to "ON" eliminates interruption of the output video when the output mode is switched. * On output channels for which "OUTPUT1 SYNC" is set to "ON," the output resolution is the same as OUTPUT1. * When the output mode is set to the ROTATION mode, the output picture is not interrupted, but may experience momentary corruption. |
| | TEST PATTERN | OFF , 75%.COLOR.BAR, 100%.COLOR.BAR, RAMP, STEP, HATCH, 75%COLORBAR-SP, 100%COLORBAR-SP, RAMP-SP, STEP-SP, HATCH-SP, FRAME | This outputs a test pattern. |

(*12): The guide is displayed only in combinations described as "settable" in the following table.

| MODE | OUTPUT-1 | OUTPUT-2 | OUTPUT-3 | OUTPUT-4 |
|---|----------|----------|----------|----------|
| MATRIX | settable | settable | settable | settable |
| MULTI-2, SPAN-2 | — | — | settable | settable |
| MULTI-3, SPAN-3 | — | — | — | settable |
| DISSOLVE-1 | — | settable | settable | — |
| PGM-PST | — | settable | settable | settable |
| MULTI-4, SPAN-4, 4K-1, 4K-2, ROTATION-L1-4, ROTATION-R1-4 | — | — | — | — |

* No guide is displayed during output of a still image.

(*13): "OUTPUT 1 SYNC" can be set using OUTPUT-2 through 4.

TRANSITION

| Menu item | | Value | Description |
|-------------|-----------|-----------------------------------|---|
| 2nd level | 3rd level | | |
| TIME | — | 0.0 sec- 1.0 sec -10.0 sec | This adjusts the video transition time/fade time. |

OFF SWITCH

| Menu item | | Value | Description |
|---------------------|-----------|----------------|---|
| 2nd level | 3rd level | | |
| RED | — | 0 -255 | This adjusts the red level of the monochrome picture during a fade. |
| GREEN | — | 0 -255 | This adjusts the green level of the monochrome picture during a fade. |
| BLUE | — | 0 -255 | This adjusts the blue level of the monochrome picture during a fade. |
| AUDIO FOLLOW | — | OFF, ON | This sets the Audio Follow feature on or off. |

MULTI (*14)

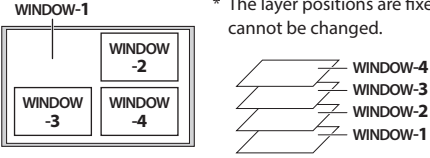
| Menu item | | Value | Description |
|---------------------------|--|-------------------------------------|--|
| 2nd level | 3rd level | | |
| WINDOW-1 : WINDOW-4 | SOURCE CH (*15) | CH1-CH8 | <p>This sets the video input channels displayed in the respective windows during video compositing.</p>  <p>* The layer positions are fixed and cannot be changed.</p> |
| | SIZE | 10 %-100 % | This adjusts the size of the window. |
| | POSITION H | -100 %-100 % | This adjusts the horizontal position of the window. |
| | POSITION V | -100 %-100 % | This adjusts the vertical position of the window. |
| | CROPPING TYPE | ORIGINAL, 4: 3, 5: 4, 16: 9, MANUAL | This selects the type when cropping a window. |
| | MANUAL H (*16) | -2000-0-2000 | This sets the horizontal cropping width. |
| | MANUAL V (*16) | -2000-0-2000 | This sets the vertical cropping width. |
| | ZOOM | 100 %-1000 % | This adjusts the enlargement factor of the picture. |
| | ZOOM POSITION H | -1920-0-1920 | This adjusts the horizontal display position of the video. |
| | ZOOM POSITION V | -1920-0-1920 | This adjusts the vertical display position of the video. |
| | OUTPUT1 SW : OUTPUT4 SW * This varies according to model. | OFF, ON | <p>This sets whether windows for each output channel are displayed (ON) or hidden (OFF).</p> <p>* Separately adjusting the size and position of the window for each output channel is not possible.</p> |

(*14): Effective when "MODE" is set to a value from "MULTI-2" to "MULTI-4."

(*15): The "SOURCE CH" setting can be changed only for the windows in multi-view output. For example, when "MODE" is set to "MULTI-2," only WINDOW-1 and WINDOW-2 can be changed.

(*16): Effective when "CROPPING TYPE" under "MULTI" is set to "MANUAL."

AUDIO INPUT

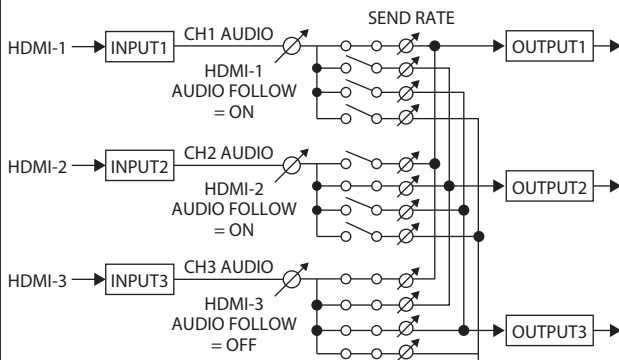
| Menu item | | Value | Description |
|--|--------------|--|---|
| 2nd level | 3rd level | | |
| HDMI-1 : HDMI-8 ANALOG-1 : ANALOG-8 | INPUT LEVEL | 0 (-INF dB)-100 (0.0 dB)-127 (+6.0 dB) | This adjusts the volume level of input audio. |
| | INPUT MUTE | OFF, ON | This sets the Mute feature on or off. Input audio for which this is set to "ON" is silenced. |
| | AUDIO FOLLOW | OFF, ON | <p>This sets the Audio Follow feature on or off.</p> <p>ON: Selected audio is sent to a single output channel.</p> <p>OFF: Audio on each output channel is sent to all channels. (*17)</p>  |

(*17): Setting "AUDIO FOLLOW" to "OFF" during input or output of copyright-protected (HDCP) video might result in no audio output on other channels. For details, refer to "Important Notes When Working with Copyright-protected (HDCP) Video" (p. 17).

AUDIO INPUT (continued)

| Menu item | | Value | Description |
|--|------------------------|---|---|
| 2nd level | 3rd level | | |
| ANALOG-1 ANALOG-2 | PHANTOM POWER | OFF, ON | This sets phantom power on or off (R channel only). |
| | INPUT GAIN | 0 dB–64 dB | This adjusts the input sensitivity (R channel only). |
| | MONO INPUT | OFF, ON | Setting this to “ON” enables monaural input. |
| ANALOG-1 : ANALOG-8 | HPF | OFF, ON | This sets the high-pass filter on or off. Setting this to “ON” attenuates the low band while passing the high band unchanged. |
| HDMI-1 : HDMI-8 ANALOG-1 : ANALOG-8 | 4BAND EQUALIZER | OFF, ON | This sets the equalizer on or off. |
| | HIGH GAIN | -15 dB–0 dB–15 dB | This boosts or attenuates the high band. |
| | HIGH FREQ | 600 Hz–8.00 kHz–12.0 kHz | This adjusts the center frequency when changing the sound quality in the high band. |
| | HI-MID GAIN | -15 dB–0 dB–15 dB | This boosts or attenuates the high-midrange band. |
| | HI-MID FREQ | 20.0 Hz–2.50 kHz–10.0 kHz | This adjusts the center frequency when changing the sound quality in the high-midrange band. |
| | HI-MID Q | 0.50–1.00–16.0 | This adjusts the bandwidth when boosting or attenuating the high-midrange band. |
| | LOW-MID GAIN | -15 dB–0 dB–15 dB | This boosts or attenuates the low-midrange band. |
| | LOW-MID FREQ | 20.0 Hz–2.50 kHz–10.0 kHz | This adjusts the center frequency when changing the sound quality in the low-midrange band. |
| | LOW-MID Q | 0.50–1.00–16.0 | This adjusts the bandwidth when boosting or attenuating the low-midrange band. |
| | LOW GAIN | -15 dB–0 dB–15 dB | This boosts or attenuates the low band. |
| | LOW FREQ | 50.0 Hz–112 Hz–800 Hz | This adjusts the center frequency when changing the sound quality in the low band. |
| | GATE | OFF, ON | This sets gate on or off. |
| | THRESHOLD | -50 dB– -48 dB–0 dB | This sets the level used as the threshold for removing audio. Audio that does not reach the threshold level is removed. |
| | RELEASE | 30 ms–500 ms–5000 ms | This adjusts the length of time until the gate effect ends after audio falls below the threshold. |
| | COMPRESSOR/ DUCKING | OFF, COMPRESSOR, DUCKING | This sets the compressor or ducking on or off. |
| | THRESHOLD | -50 dB– -16 dB–0 dB | This sets the level used as the threshold when performing audio compression (compressor) or attenuation (ducking). Compressor: Compression is applied to audio that exceeds the threshold level. Ducking: Audio that exceeds the threshold level is attenuated. |
| | COMP-RATIO | 1.0: 1, 1.2: 1, 1.5: 1, 2.0: 1, 2.8: 1, 4.0: 1, 8.0: 1, 16: 1, INF: 1 | This specifies the degree of compression applied to the audio. The state in which no compression is applied is defined as “1.” |
| | COMP-ATTACK | 0.2 ms–50 ms–100 ms | This sets the time until the compression effect peaks after audio exceeding the threshold is input. |
| | COMP-KNEE | HARD, SOFT1–SOFT9 | This adjusts the way in which the compressor is applied to the region near the threshold level within a range extending from steep (HARD) to gentle (SOFT9). |
| | COMP-RELEASE | 30 ms–500 ms–5000 ms | This adjusts the length of time until compression ends after audio falls below the threshold. |
| | DUCK-KEY IN SELECT | HDMI INPUT1–8, ANALOG INPUT1–8 * Default values differ according to input channel. | This sets the channel to use as the key-in signal. |
| DUCK-ATTACK | 0.2 ms–50 ms–100 ms | This sets the time until the ducking effect peaks after audio exceeding the threshold is input. | |
| DUCK-RELEASE | 30 ms–500 ms–5000 ms | This adjusts the time until the ducking effect disappears after the time set for “DUCK-HOLD” has passed. | |
| DUCK-HOLD | 0 ms–250 ms–5000 ms | This adjusts the length of time until the ducking effect starts to end after audio falls below the threshold. | |
| OUT1 SEND RATE : OUT4 SEND RATE * This varies according to model. | 0 %–100 % | This sets the audio send level for the respective output channel. | |

AUDIO OUTPUT

| Menu item | | Value | Description |
|--|-----------------|---|--|
| 2nd level | 3rd level | | |
| OUTPUT-1 : OUTPUT-4 * This varies according to model. | OUTPUT LEVEL | 0 (-INF dB)– 100 (0.0 dB) –127 (+6.0 dB) | This adjusts the volume level of output audio. |
| | OUTPUT MUTE | OFF , ON | This sets the Mute feature on or off. Output audio for which this is set to "ON" is silenced. |
| | OUTPUT DELAY | 0 ms– 60 ms –170 ms | This adjusts the delay time for output audio. |
| | HDMI AUDIO CH | 2ch , 5.1ch, 7.1ch | This sets the number of audio channels output via the HDMI OUTPUT connector. |
| | DOWN MIX | OFF , STEREO > MONO, 5.1ch > STEREO, 5.1ch > MONO | This sets downmixing on or off. STEREO > MONO: This downmixes stereo audio and outputs it as monaural. 5.1ch > STEREO: This downmixes 5.1-channel audio and outputs it as stereo. 5.1ch > MONO: This downmixes 5.1-channel audio and outputs it as monaural. |
| | 4BAND EQUALIZER | OFF , ON | This sets the equalizer on or off. |
| | HIGH GAIN | -15 dB– 0 dB –15 dB | This boosts or attenuates the high band. |
| | HIGH FREQ | 600 Hz– 8.00 kHz –12.0 kHz | This adjusts the center frequency when changing the sound quality in the high band. |
| | HI-MID GAIN | -15 dB– 0 dB –15 dB | This boosts or attenuates the high-midrange band. |
| | HI-MID FREQ | 20.0 Hz– 2.50 kHz –10.0 kHz+ | This adjusts the center frequency when changing the sound quality in the high-midrange band. |
| | HI-MID Q | 0.50– 1.00 –16.0 | This adjusts the bandwidth when boosting or attenuating the high-midrange band. |
| | LOW-MID GAIN | -15 dB– 0 dB –15 dB | This boosts or attenuates the low-midrange band. |
| | LOW-MID FREQ | 20.0 Hz– 2.50 kHz –10.0 kHz | This adjusts the center frequency when changing the sound quality in the low-midrange band. |
| | LOW-MID Q | 0.50– 1.00 –16.0 | This adjusts the bandwidth when boosting or attenuating the low-midrange band. |
| | LOW GAIN | -15 dB– 0 dB –15 dB | This boosts or attenuates the low band. |
| | LOW FREQ | 50.0 Hz– 112 Hz –800 Hz | This adjusts the center frequency when changing the sound quality in the low band. |
| | GATE/COMPRESSOR | OFF , GATE, COMPRESSOR | This sets the gate or compressor on or off. |
| | GATE-THRESHOLD | -50 dB– -48 dB –0 dB | This sets the level used as the threshold for removing audio. Audio that does not reach the threshold level is removed. |
| | GATE-RELEASE | 30 ms– 500 ms –5000 ms | This adjusts the length of time until the gate effect ends after audio falls below the threshold. |
| | COMP-THRESHOLD | -50 dB– -16 dB –0 dB | This sets the level used as the threshold when performing audio compression. Compression is applied to audio that exceeds the threshold level. |
| | COMP-RAITO | 1.0: 1, 1.2: 1, 1.5: 1, 2.0: 1, 2.8: 1 , 4.0: 1, 8.0: 1, 16: 1, INF: 1 | This specifies the degree of compression applied to the audio. The state in which no compression is applied is defined as "1." |
| | COMP-ATTACK | 0.2 ms– 50 ms –100 ms | This sets the time until the compression effect peaks after audio exceeding the threshold is input. |
| | COMP-KNEE | HARD , SOFT1–SOFT9 | This adjusts the way in which the compressor is applied to the region near the threshold level within a range extending from steep (HARD) to gentle (SOFT9). |
| | COMP-RELEASE | 30 ms– 500 ms –5000 ms | This adjusts the length of time until compression ends after audio falls below the threshold. |
| | TEST TONE | OFF , ON | Setting this to "ON" outputs a test tone. The frequency of the test tone is fixed at 1 kHz (+4 dBu). |

AUDIO CONTROL

| Menu item | | Value | Description |
|--------------|-----------|---|--|
| 2nd level | 3rd level | | |
| FADER 1 | — | HDMI INPUT1–8, ANALOG INPUT1–8 | These set the audio input channels assigned to audio faders 1 through 8 at the audio volume control screen. |
| FADER 2 | — | HDMI INPUT1–HDMI INPUT2–8, ANALOG INPUT1–8 | |
| FADER 3 | — | HDMI INPUT1–HDMI INPUT3–8, ANALOG INPUT1–8 | |
| FADER 4 | — | HDMI INPUT1–HDMI INPUT4–8, ANALOG INPUT1–8 | |
| FADER 5 | — | HDMI INPUT1–HDMI INPUT5–8, ANALOG INPUT1–8 | |
| FADER 6 | — | HDMI INPUT1–HDMI INPUT6–8, ANALOG INPUT1–8 | |
| FADER 7 | — | HDMI INPUT1–HDMI INPUT7–8, ANALOG INPUT1–8 | |
| FADER 8 | — | HDMI INPUT1–HDMI INPUT8, ANALOG INPUT1–8 | |
| OUTPUT FADER | — | ALL, OUTPUT1–4 | This sets the audio output channel assigned to the output fader at the audio volume control screen. Setting this to “ALL” lets you adjust the audio on all audio output channels simultaneously. |

MODE

| Menu item | | Value | Description |
|-----------|-----------|--|---|
| 2nd level | 3rd level | | |
| MODE | — | MATRIX, MULTI-2, MULTI-3, MULTI-4, SPAN-2, SPAN-3 (*18), SPAN-4 (*19), ROTATION-L1, ROTATION-L2, ROTATION-L3 (*18), ROTATION-L4 (*19), ROTATION-R1, ROTATION-R2, ROTATION-R3 (*18), ROTATION-R4 (*19), 4K-1 (*18), 4K-2 (*19), DISSOLVE-1, PGM-PST | <p>This sets the video output mode.</p> <p>* On output channels for which “OUTPUT1 SYNC” under “VIDEO OUTPUT” is set to “ON,” the output video is not interrupted during mode switching.</p> <p>* For the output images of the respective output modes, refer to the Owner’s Manual, “Switching the Video Output Mode” (p. 22).</p> |

(*18): XS-83H/XS-84H only

(*19): XS-84H only

PRESET MEMORY

| Menu item | | Value | Description | | | | | | | | | | | | | | | | | | | | | | | | | | | | | | | | | | | | |
|----------------|-----------|--|---|---------------|-------|-------------|-------------|---------|--|--------------|---------|-----------------------|----------------|---------|---------------------------|------------|---------|---|------------|---------|-----------------------|-------|---------|---------------------|-------------|---------|----------------------|--------------|---------|-----------------------|---------------|---------|--|------|---------|----------------------|------------|---------|---------------------------------------|
| 2nd level | 3rd level | | | | | | | | | | | | | | | | | | | | | | | | | | | | | | | | | | | | | | |
| LOAD SETTING | — | 1–32 | This loads the settings at the specified preset number. | | | | | | | | | | | | | | | | | | | | | | | | | | | | | | | | | | | | |
| RECALL SAFE | — | OFF, ON | <p>Setting this to “ON” recalls only the specified settings from the preset.</p> <p>Setting this to “ON” and pressing the [VALUE] dial displays the “RECALL SAFE” popup. Specify whether the settings for the following items are individually recalled (OFF) or not individually recalled (ON).</p> <table border="1"> <thead> <tr> <th>Setting items</th> <th>Value</th> <th>Description</th> </tr> </thead> <tbody> <tr> <td>VIDEO INPUT</td> <td>OFF, ON</td> <td>Video input settings, input EDID assignment settings</td> </tr> <tr> <td>VIDEO OUTPUT</td> <td>OFF, ON</td> <td>Video output settings</td> </tr> <tr> <td>OUT RESOLUTION</td> <td>OFF, ON</td> <td>Output resolution setting</td> </tr> <tr> <td>TRANSITION</td> <td>OFF, ON</td> <td>Video transition time/fade time setting</td> </tr> <tr> <td>OFF SWITCH</td> <td>OFF, ON</td> <td>[OFF] button settings</td> </tr> <tr> <td>MULTI</td> <td>OFF, ON</td> <td>Multi-view settings</td> </tr> <tr> <td>AUDIO INPUT</td> <td>OFF, ON</td> <td>Audio input settings</td> </tr> <tr> <td>AUDIO OUTPUT</td> <td>OFF, ON</td> <td>Audio output settings</td> </tr> <tr> <td>AUDIO CONTROL</td> <td>OFF, ON</td> <td>Fader assignment settings at the audio volume control screen</td> </tr> <tr> <td>MODE</td> <td>OFF, ON</td> <td>Output mode settings</td> </tr> <tr> <td>CROSSPOINT</td> <td>OFF, ON</td> <td>Cross-point selection button settings</td> </tr> </tbody> </table> | Setting items | Value | Description | VIDEO INPUT | OFF, ON | Video input settings, input EDID assignment settings | VIDEO OUTPUT | OFF, ON | Video output settings | OUT RESOLUTION | OFF, ON | Output resolution setting | TRANSITION | OFF, ON | Video transition time/fade time setting | OFF SWITCH | OFF, ON | [OFF] button settings | MULTI | OFF, ON | Multi-view settings | AUDIO INPUT | OFF, ON | Audio input settings | AUDIO OUTPUT | OFF, ON | Audio output settings | AUDIO CONTROL | OFF, ON | Fader assignment settings at the audio volume control screen | MODE | OFF, ON | Output mode settings | CROSSPOINT | OFF, ON | Cross-point selection button settings |
| Setting items | Value | Description | | | | | | | | | | | | | | | | | | | | | | | | | | | | | | | | | | | | | |
| VIDEO INPUT | OFF, ON | Video input settings, input EDID assignment settings | | | | | | | | | | | | | | | | | | | | | | | | | | | | | | | | | | | | | |
| VIDEO OUTPUT | OFF, ON | Video output settings | | | | | | | | | | | | | | | | | | | | | | | | | | | | | | | | | | | | | |
| OUT RESOLUTION | OFF, ON | Output resolution setting | | | | | | | | | | | | | | | | | | | | | | | | | | | | | | | | | | | | | |
| TRANSITION | OFF, ON | Video transition time/fade time setting | | | | | | | | | | | | | | | | | | | | | | | | | | | | | | | | | | | | | |
| OFF SWITCH | OFF, ON | [OFF] button settings | | | | | | | | | | | | | | | | | | | | | | | | | | | | | | | | | | | | | |
| MULTI | OFF, ON | Multi-view settings | | | | | | | | | | | | | | | | | | | | | | | | | | | | | | | | | | | | | |
| AUDIO INPUT | OFF, ON | Audio input settings | | | | | | | | | | | | | | | | | | | | | | | | | | | | | | | | | | | | | |
| AUDIO OUTPUT | OFF, ON | Audio output settings | | | | | | | | | | | | | | | | | | | | | | | | | | | | | | | | | | | | | |
| AUDIO CONTROL | OFF, ON | Fader assignment settings at the audio volume control screen | | | | | | | | | | | | | | | | | | | | | | | | | | | | | | | | | | | | | |
| MODE | OFF, ON | Output mode settings | | | | | | | | | | | | | | | | | | | | | | | | | | | | | | | | | | | | | |
| CROSSPOINT | OFF, ON | Cross-point selection button settings | | | | | | | | | | | | | | | | | | | | | | | | | | | | | | | | | | | | | |
| SAVE SETTING | — | 1–32 | This saves settings at the specified preset number. | | | | | | | | | | | | | | | | | | | | | | | | | | | | | | | | | | | | |
| DELETE SETTING | — | 1–32 | This deletes the settings at the specified preset number. | | | | | | | | | | | | | | | | | | | | | | | | | | | | | | | | | | | | |

EDID

| Menu item | | Value | Description |
|---------------------------------------|-----------|--|--|
| 2nd level | 3rd level | | |
| HDMI EDID IN-1 : HDMI EDID IN-8 | — | <ul style="list-style-type: none"> When "FRAME RATE" under "SYSTEM" is set to "59.94 Hz" INTERNAL, 640 x 480, 800 x 600, 1024 x 768, 1280 x 768, 1366 x 768, 1280 x 1024, 1400 x 1050, 1600 x 1200, 1920 x 1200, DATA1-8 (*20), 480i 4:3, 480i 16:9, 480p 4:3, 480p 16:9, 720p, 1080i, 1080p When "FRAME RATE" under "SYSTEM" is set to "50 Hz" INTERNAL, 640 x 480, 800 x 600, 1024 x 768, 1280 x 768, 1366 x 768, 1280 x 1024, 1400 x 1050, 1600 x 1200, 1920 x 1200, DATA1-8(*20), 576i 4:3, 576i 16:9, 576p 4:3, 576p 16:9, 720p, 1080i, 1080p | <p>These set the EDID values for HDMI INPUT.</p> <p>INTERNAL: Information on computer-use input resolution and video-use input resolution is sent. (Refer to the chart below.)</p> <p>DATA1-8: EDID values copied using "HDMI EDID COPY" are sent. (Refer to the chart below.)</p> <p>* Supported audio formats are shared by "INTERNAL" through "1920 x 1200." For details, refer to the chart below.</p> <p>* Pressing the [VALUE] dial after changing settings displays a popup prompting you to confirm the changes. Pressing the [VALUE] dial applies the changes to the settings.</p> |
| RGB EDID IN-1 : RGB EDID IN-8 | — | <p>INTERNAL, 640 x 480, 800 x 600, 1024 x 768, 1280 x 768, 1366 x 768, 1280 x 1024, 1400 x 1050, 1600 x 1200, 1920 x 1200</p> | <p>These set the EDID values for RGB INPUT.</p> <p>INTERNAL: Information on computer-use input resolution is sent. (Refer to the chart below.)</p> <p>* Pressing the [VALUE] dial after changing settings displays a popup prompting you to confirm the changes. Pressing the [VALUE] dial applies the changes to the settings.</p> |
| EDID COPY OUTPUT | — | OUTPUT1-4 * This varies according to model. | This selects the HDMI OUTPUT connector for copying the EDID. |
| HDMI EDID COPY | — | DATA1-8 | <p>Specifying a copy destination (DATA1 through 8) and pressing the [VALUE] dial displays the "HDMI EDID COPY" popup.</p> <p>This copies the EDID of the display connected to the HDMI OUTPUT connector selected using "EDIT COPY OUTPUT."</p> |

(*20): The "DATA1-8" settings are not saved at individual presets. Only a single set is saved in the unit. After settings for menu items have been made, the new values are saved in the unit's internal memory when you exit the menu.

Data Sent When Set to "INTERNAL"

● When frame rate is set to "59.94 Hz"

| Computer-use input resolution | | | |
|---------------------------------------|-------------------------|------------------------------|---|
| 640 x 480/60 Hz (VGA) | 800 x 600/60 Hz (SVGA) | 1024x768/60 Hz (XGA) | 1280x800/60 Hz (WXGA) |
| 1280 x 1024/60 Hz (SXGA) | 1400x1050/60 Hz (SXGA+) | 1600x1200/60 Hz (UXGA) | 1920x1200/60Hz (Reduced Blanking) (WUXGA) |
| 1280 x 768/60 Hz (WXGA) | 1366x768/60 Hz (FWXGA) | 1920x1080/59.94p, 60p | 1920x1080/59.94i |
| Video-use input resolution | | | |
| 1920x1080/59.94p, 60p (16:9) [Native] | 1920x1080/50p (16:9) | 1920x1080/59.94i, 60i (16:9) | 1920x1080/50i (16:9) |
| 1280x720/59.94p, 60p (16:9) | 1280x720/50p (16:9) | 720x480/59.94p, 60p (16:9) | 720x480/59.94p, 60p (4:3) |
| 720x576/50p (16:9) | 720x576/50p (4:3) | 720x480/59.94i (16:9) | 720x480/59.94i (4:3) |
| 720x576/50i (16:9) | 720x576/50i (4:3) | | |

● When frame rate is set to "50 Hz"

| Computer-use input resolution | | | |
|-------------------------------|--|------------------------------|---------------------------|
| 640x480/60 Hz (VGA) | 640x480/75 Hz (VGA) | 800x600/60 Hz (SVGA) | 800x600/75 Hz (SVGA) |
| 1024x768/60 Hz (XGA) | 1024x768/75 Hz (XGA) | 1280x800/60 Hz (WXGA) | 1280x800/75 Hz (WXGA) |
| 1280x1024/60Hz (SXGA) | 1280x1024/75 Hz (SXGA) | 1400x1050/60 Hz (SXGA+) | 1400x1050/75 Hz (SXGA+) |
| 1600x1200/60 Hz (UXGA) | 1920x1200/60 Hz (Reduced Blanking) (WUXGA) | 1280x768/60 Hz (WXGA) | 1366x768/60 Hz (FWXGA) |
| 1920x1080/59.94p, 60p | 1920x1080/59.94i | | |
| Video-use input resolution | | | |
| 1920x1080/59.94p, 60p (16:9) | 1920x1080/50p (16:9) [Native] | 1920x1080/59.94i, 60i (16:9) | 1920x1080/50i (16:9) |
| 1280x720/59.94p, 60p (16:9) | 1280x720/50p (16:9) | 720x480/59.94p, 60p (16:9) | 720x480/59.94p, 60p (4:3) |
| 720x576/50p (16:9) | 720x576/50p (4:3) | 720x480/59.94i (16:9) | 720x480/59.94i (4:3) |
| 720x576/50i (16:9) | 720x576/50i (4:3) | | |

● Supported audio format

Linear PCM/48 kHz/24 bits/8 channels

* Speaker configurations are as follows.

- Front Left/Front Right
- Front Center
- Rear Left/Rear Right
- Rear Left Center/Rear Right Center
- LFE

* The settings for the following menu items are not saved at individual presets. Only a single set is saved in the unit. After settings for menu items have been made, the new values are saved in the unit's internal memory when you exit the menu.

RS-232C

| Menu item | | Value | Description |
|-----------|-----------|---|---|
| 2nd level | 3rd level | | |
| BAUD RATE | — | 9600, 38400 | This sets the communication speed (bps) of the RS-232C connector. |
| FUNCTION | — | RECEIVER, HDBaseT1, HDBaseT2, HDBaseT3, HDBaseT4 * This varies according to model. | This specifies the functioning of the RS-232C connector. RECEIVER: The unit receives commands via the RS-232C interface and is operated remotely. HDBaseT1-4: Commands sent and received via RS-232C are sent and received unchanged via the specified HDBaseT connector. The unit is not under remote control. |

LAN

| Menu item | | Value | Description |
|------------------|-----------|----------------------|---|
| 2nd level | 3rd level | | |
| CONFIGURE | — | USING DHCP, MANUALLY | This sets whether the IP address is obtained automatically (USING DHCP) or set manually (MANUALLY). |
| IP ADDRESS (*18) | — | 192.168.2.254 | This sets the IP address. * The subnet mask is fixed at "255.255.255.0" and cannot be changed. |
| INFORMATION | — | (ENTER) | Pressing the [VALUE] dial displays the "LAN INFORMATION" popup. This displays the setting information for the LAN (p. 18). |

(*21): Effective when "CONFIGURE" is set to "MANUALLY"

WIRELESS LAN

| Menu item | | Value | Description |
|--------------|-----------|---------|---|
| 2nd level | 3rd level | | |
| ACCESS POINT | — | (ENTER) | Pressing the [VALUE] dial displays the "ACCESS POINT" popup. From the list of wireless LAN access points, you select the Wi-Fi router to connect to. |
| WPS | — | (ENTER) | Pressing the [VALUE] dial displays the "WPS" popup. This establishes a WPS connection to the Wi-Fi router. |
| AD-HOC MODE | — | OFF, ON | This sets the ad-hoc mode on or off. |
| AD-HOC CH | — | 1-11 | This sets the channel of the ad-hoc mode. |
| WIRELESS ID | — | 0-99 | This sets the wireless ID. * The wireless ID is a setting shared by the wired LAN and the wireless LAN. |
| INFORMATION | — | (ENTER) | Pressing the [VALUE] dial displays the "WLAN INFORMATION" popup. This displays the Wi-Fi setting information (p. 16). |

USB MEMORY

| Menu item | | Value | Description |
|------------------|-----------|---------|---|
| 2nd level | 3rd level | | |
| LOAD PRESET | — | (ENTER) | Pressing the [VALUE] dial displays the "LOAD PRESET" popup. This loads into the unit a settings file saved on a USB flash drive. |
| SAVE PRESET | — | (ENTER) | Pressing the [VALUE] dial displays the "SAVE PRESET" popup. Any settings file already saved on the USB flash drive is overwritten. |
| SAVE AS PRESET | — | (ENTER) | Pressing the [VALUE] dial displays the "SAVE AS PRESET" popup. This saves the settings file to the USB flash drive with a name assigned to it. |
| LOAD STILL IMAGE | — | 1-4 | Selecting a still-image save destination from 1 to 4 and pressing the [VALUE] dial displays the "LOAD STILL IMAGE" popup. At the popup, you select a file and load the still image into the unit. |
| FORMAT | — | (ENTER) | This formats a USB flash drive. |

* The settings for the following menu items are not saved at individual presets. Only a single set is saved in the unit. After settings for menu items have been made, the new values are saved in the unit's internal memory when you exit the menu.

SYSTEM

| Menu item | | Value | Description | | | | | | | | | | | | | | | | | | | | | | |
|-------------------------------------|-----------|--|--|---------------|-------|-------------|------------|---------|-------------------------------|-------------|---------|-------------------------|-----------|---------|------------------------------|--------------|---------|--------------------------------|---------------|---------|---|-----------|---------|---------------|-------------------------------------|
| 2nd level | 3rd level | | | | | | | | | | | | | | | | | | | | | | | | |
| FRAME RATE | — | 59.94 Hz, 50 Hz | This sets the system clock. | | | | | | | | | | | | | | | | | | | | | | |
| FIELD SYNC | — | OFF, ON | This sets field sync on or off. | | | | | | | | | | | | | | | | | | | | | | |
| KEY LOCK MODE | — | (ENTER) | Pressing the [VALUE] dial displays the "KEY LOCK MODE" popup. This sets whether key locking is activated (ON) or deactivated (OFF) for each of the following buttons. | | | | | | | | | | | | | | | | | | | | | | |
| | | | <table border="1"> <thead> <tr> <th>Setting items</th> <th>Value</th> <th>Description</th> </tr> </thead> <tbody> <tr> <td>CROSSPOINT</td> <td>OFF, ON</td> <td>Cross-point selection buttons</td> </tr> <tr> <td>SWITCH MODE</td> <td>OFF, ON</td> <td>[SWITCHING MODE] button</td> </tr> <tr> <td>MENU+EXIT</td> <td>OFF, ON</td> <td>[MENU] button, [EXIT] Button</td> </tr> <tr> <td>CURSOR+VALUE</td> <td>OFF, ON</td> <td>Cursor buttons, [VALUE] button</td> </tr> <tr> <td>CROSS-NOINPUT</td> <td>OFF, ON</td> <td>Cross-point selection buttons that have no signal input</td> </tr> <tr> <td>CROSS-OFF</td> <td>OFF, ON</td> <td>[OFF] buttons</td> </tr> <tr> <td>CROSS-OUTPUT1 : CROSS-OUTPUT4</td> <td rowspan="2">OFF, ON</td> <td rowspan="2">Cross-point selection buttons for each respective OUTPUT row</td> </tr> <tr> <td>* This varies according to model.</td> </tr> </tbody> </table> <p>Operation: Turns key lock mode on/off</p> <ol style="list-style-type: none"> For "KEY LOCK MODE," set the parameter to "ON" for buttons whose operations you want to have no effect. Hold down the [EXIT] button and press and hold the [MENU] button (for 3 seconds or longer). The message "KEY LOCKED!!" is displayed and the key lock mode is turned on. The buttons you specified in step 1 are locked. Again holding down the [EXIT] button and pressing and holding the [MENU] button (for 3 seconds or longer) makes the message "KEY RELEASED!!" appear and turns off the key lock mode. | Setting items | Value | Description | CROSSPOINT | OFF, ON | Cross-point selection buttons | SWITCH MODE | OFF, ON | [SWITCHING MODE] button | MENU+EXIT | OFF, ON | [MENU] button, [EXIT] Button | CURSOR+VALUE | OFF, ON | Cursor buttons, [VALUE] button | CROSS-NOINPUT | OFF, ON | Cross-point selection buttons that have no signal input | CROSS-OFF | OFF, ON | [OFF] buttons | CROSS-OUTPUT1 : CROSS-OUTPUT4 |
| Setting items | Value | Description | | | | | | | | | | | | | | | | | | | | | | | |
| CROSSPOINT | OFF, ON | Cross-point selection buttons | | | | | | | | | | | | | | | | | | | | | | | |
| SWITCH MODE | OFF, ON | [SWITCHING MODE] button | | | | | | | | | | | | | | | | | | | | | | | |
| MENU+EXIT | OFF, ON | [MENU] button, [EXIT] Button | | | | | | | | | | | | | | | | | | | | | | | |
| CURSOR+VALUE | OFF, ON | Cursor buttons, [VALUE] button | | | | | | | | | | | | | | | | | | | | | | | |
| CROSS-NOINPUT | OFF, ON | Cross-point selection buttons that have no signal input | | | | | | | | | | | | | | | | | | | | | | | |
| CROSS-OFF | OFF, ON | [OFF] buttons | | | | | | | | | | | | | | | | | | | | | | | |
| CROSS-OUTPUT1 : CROSS-OUTPUT4 | OFF, ON | Cross-point selection buttons for each respective OUTPUT row | | | | | | | | | | | | | | | | | | | | | | | |
| * This varies according to model. | | | | | | | | | | | | | | | | | | | | | | | | | |
| MEMORY PROTECT | — | OFF, ON | Setting this to "ON" prohibits saving to presets. | | | | | | | | | | | | | | | | | | | | | | |
| RECALL LOCK | — | OFF, ON | Setting this to "ON" prohibits recalling presets. | | | | | | | | | | | | | | | | | | | | | | |
| BEEP | — | OFF, ON | This sets the audible beep on or off. | | | | | | | | | | | | | | | | | | | | | | |
| LCD BACKLIGHT | — | 0-7 | This adjusts the brightness of the display. * When this is set to "0," the display's backlight is completely dark. | | | | | | | | | | | | | | | | | | | | | | |
| DIMMER | — | 0-7 | This adjusts the brightness of the LEDs. * When this is set to "0," the LEDs are completely dark. | | | | | | | | | | | | | | | | | | | | | | |
| TOP DISPLAY | — | IN/OUT STATUS, INPUT STATUS1, INPUT STATUS2, OUTPUT STATUS , AUDIO VOLUME | This sets the top screen displayed at startup. | | | | | | | | | | | | | | | | | | | | | | |
| START UP | — | LAST MEMORY , PRESET1-32 | This sets the settings loaded at startup. LAST MEMORY: The last-saved settings are loaded. When "LAST MEMORY" has been selected, settings are saved in internal memory at the following times. <ul style="list-style-type: none"> On displaying a menu On exiting a menu When 10 seconds has elapsed since the last operation was performed | | | | | | | | | | | | | | | | | | | | | | |
| MONITOR STATUS | — | (ENTER) | Pressing the [VALUE] dial displays the "MONITOR STATUS" popup. This displays the status of equipment connected to the HDBaseT OUTPUT or HDMI OUTPUT connectors. | | | | | | | | | | | | | | | | | | | | | | |
| INPUT STATUS | — | CH1-8 | Selecting an input video channel and pressing the [VALUE] dial displays the "INPUT STATUS" popup. This displays format information for the input video. | | | | | | | | | | | | | | | | | | | | | | |
| DELETE STILL IMAGE | — | 1-4 | Selecting a still-image save destination from 1 to 4 and pressing the [VALUE] dial displays the "DELETE STILL" popup. Here you delete the still image at the save destination. | | | | | | | | | | | | | | | | | | | | | | |
| VERSION | — | — | This displays program version information for the system. | | | | | | | | | | | | | | | | | | | | | | |
| FACTORY RESET | — | (ENTER) | This returns the unit's settings to their factory defaults. | | | | | | | | | | | | | | | | | | | | | | |

Network Settings

Network Functions

USB WLAN ADAPTOR Connector

Attaching an optional wireless USB adaptor to the USB WLAN ADAPTOR port lets you operate the unit remotely using the XS-80H Remote iPad application.

- * For the wireless USB adaptor, use the ONKYO UWF-1 or Roland WNA1100-RL.

You can use either of the following two methods to make the Wi-Fi connection.

- ① Direct connection to the iPad (ad-hoc mode) → p. 14

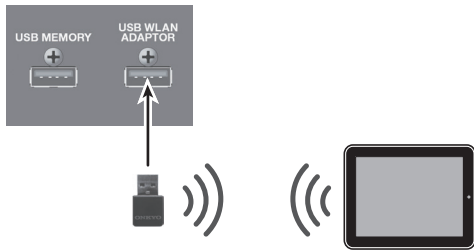

- ② Connection through a Wi-Fi router

You make a wireless connection between the unit and a Wi-Fi router, and make a wireless connection to the iPad via the router.

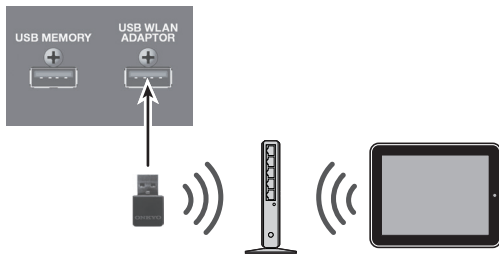

→ Connecting to a Wi-Fi Router by WPS: p. 15

→ Selecting and Connecting to a Wi-Fi Router: p. 15

LAN Port

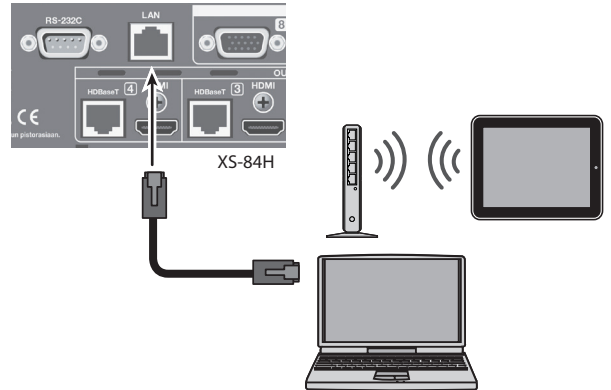

You can operate the unit remotely using TCP control commands from a computer, network device, or other such external equipment connected via the LAN port.

For details, refer to "Control Using the LAN Port" (p. 18).

You can also use the XS-80H Remote iPad application to operate the unit remotely via a Wi-Fi router connected to the LAN port.

For details, refer to "Making a Wired Connection to the Wi-Fi Router" (p. 16).

Connecting via Wi-Fi

Preparations

To make the connections over Wi-Fi, have the following equipment on hand.

- Wireless USB adaptor (ONKYO UWF-1 or Roland WNA1100-RL, sold separately)
- iPad
- Wi-Fi router (wireless LAN router, etc.) (*1) (*2)

(*1) Connection with all Wi-Fi routers is not assured.

(*2) This is not required when connecting in ad-hoc mode (p. 14).

Checking the Wi-Fi Connection Status

Wi-Fi connection status is shown by an icon at the top right of the display.

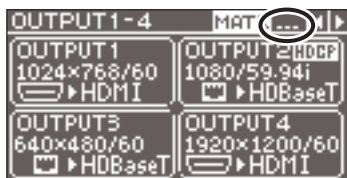

| Icon | Description |
|------|---|
| | Connected to the Wi-Fi router. The signal strength (the strength of the radio waves from the Wi-Fi router) is indicated by three bars. |
| | A wireless USB adaptor is attached, but no connection to the Wi-Fi router is in effect. |
| | No wireless USB adaptor is attached. |
| | In ad-hoc mode. |

Directly Connecting the Unit and the iPad (Ad-hoc Mode)

This makes a direct wireless connection between the unit and the iPad without using a Wi-Fi router (ad-hoc mode).

NOTE

The iPad connected in ad-hoc mode cannot connect to the Internet or communicate with other Wi-Fi devices.

1. Insert the optional wireless USB adaptor into the unit's USB WLAN ADAPTOR port.

For the wireless USB adaptor, use the ONKYO UWF-1 or Roland WNA1100-RL.

2. Use the [MENU] button to select "WIRELESS LAN," then set "AD-HOC MODE" to "ON."

This turns on ad-hoc mode.

3. From the WIRELESS LAN menu, select "INFORMATION," then press the [VALUE] dial.

The "WLAN INFORMATION" popup (p. 16) appears.

The following information is required when making the connection to the iPad.

| Indication | Description |
|------------|-------------------------------|
| SSID | This displays the SSID. |
| AD-HOC KEY | This displays the ad-hoc key. |

MEMO

When connecting multiple units of the same model, to distinguish between SSIDs, set the wireless ID on each device. For details, refer to "Setting the Wireless ID" (p. 16).

4. On the iPad, make the network settings.

1 On the iPad, tap "Settings" → "Wi-Fi" and make sure "Wi-Fi" is turned on, then for "Device," select the SSID displayed in the "WLAN INFORMATION" popup on the unit.

2 If a screen for entering a password appears, enter the ad-hoc key displayed in the "WLAN INFORMATION" popup on the unit.

MEMO

- If the connection cannot be made smoothly, changing the channel of the ad-hoc mode on the unit might help. Use the [MENU] button to select "WIRELESS LAN" → "AD-HOC CH," and change the ad-hoc mode channel (1 through 11).
- When you're not making a connection in ad-hoc mode, return the iPad's "Settings" → "Wi-Fi" settings to their original values.

5. Press the [MENU] button to quit the menu.

Connecting to a Wi-Fi Router by WPS

This connects the unit and Wi-Fi router by using WPS. "WPS" is a feature that makes it easy to connect to a Wi-Fi router and make security-related settings.

MEMO

- The Wi-Fi router you're using must support WPS.
- When a WPS connection is made to a Wi-Fi router, the connection information is saved in memory, and thereafter the connection is established automatically.

1. Insert the optional wireless USB adaptor into the unit's USB WLAN ADAPTOR port.

For the wireless USB adaptor, use the ONKYO UWF-1 or Roland WNA1100-RL.

2. Wait until the icon shown below appears at the upper right of the unit's display.

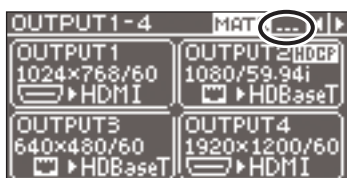

3. Use the [MENU] button to select "WIRELESS LAN" → "WPS," then press the [VALUE] dial.

The "WPS" popup appears.

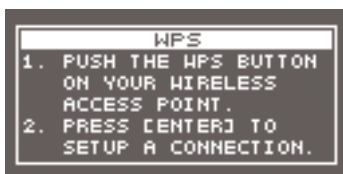

4. Enable WPS on the Wi-Fi router (e.g., press the router's WPS button).

- * To enable WPS on the Wi-Fi router, refer to the documentation for the router.

5. Press the [VALUE] dial.

The WPS connection is established. When connection is successful, the "WPS" popup disappears and the unit returns to the WIRELESS LAN menu.

6. Press the [MENU] button to quit the menu.

7. Connect the iPad and the Wi-Fi router.

- 1 On the iPad, tap "Settings" → "Wi-Fi," make sure Wi-Fi is turned on, then at "Choose a Network," select the Wi-Fi router to which the unit is connected.

Selecting and Connecting to a Wi-Fi Router

From the list of Wi-Fi access points, select the Wi-Fi router where you want to connect the unit.

- * The 802.11g/n (2.4-GHz) wireless protocols and WPS and WPS2 authentication methods are supported.
- * For information on how to operate the Wi-Fi router, refer to the router's documentation.

1. Insert the optional wireless USB adaptor into the unit's USB WLAN ADAPTOR port.

For the wireless USB adaptor, use the ONKYO UWF-1 or Roland WNA1100-RL.

2. Use the [MENU] button to select "WIRELESS LAN" → "ACCESS POINT," then press the [VALUE] dial.

The "ACCESS POINT" popup appears.

- The number of the currently selected Wi-Fi router is highlighted.
- Names that use other than single-byte alphanumeric characters are not displayed correctly.

3. Select the Wi-Fi router you want to connect to and press the [VALUE] dial.

- **When the Wi-Fi router is one you're connecting to for the first time**

The "PASSPHRASE" popup appears. Go on to step 4.



- **When the Wi-Fi router is one that you've connected to in the past**

The connection is made as soon as you select the Wi-Fi router. When a successful connection is made, the unit returns to the WIRELESS LAN menu. Go on to step 7.

Entering Security Data

- * This procedure is necessary only when the Wi-Fi router is one you're connecting to for the first time.

4. Enter the security data (passphrase) for the Wi-Fi router.

Pressing the [VALUE] dial lets you change the character at the cursor location. Turn the [VALUE] dial to change the character, then press the [VALUE] dial to apply the change.

| | |
|-----------------------|--|
| Moving the cursor | Turn the [VALUE] dial. The cursor moves forward or backward. |
| Inserting a character | Press the [◀] button. The same character as the one just before the cursor location is inserted. |
| Deleting a character | Press the [▶] button. The character at the cursor location is deleted. |

5. When you've finished entering the text, press the [EXIT] button.

6. Check the message and press the [VALUE] dial.

(If you want to quit, press the [EXIT] button.) When a successful connection is made, the unit returns to the WIRELESS LAN menu.

7. Press the [MENU] button to quit the menu.

8. Connect the iPad and the Wi-Fi router.

- 1 On the iPad, tap "Settings" → "Wi-Fi," make sure Wi-Fi is turned on, then at "Choose a Network," select the Wi-Fi router to which the unit is connected.

Setting the Wireless ID

Here you set the device name and SSID for the Wi-Fi-connected unit displayed in the XS-80H Remote iPad application.

When multiple units are on the network, you can change the device names and SSIDs by setting wireless IDs within a range of 1 to 99.

The XS-84H is used in the following example.

Wireless ID = 0: "XS-84H" (default)

Wireless ID = 1: "XS-84H-1"

:

Wireless ID = 99: "XS-84H-99"

* The wireless ID is a setting shared by the wired LAN and the wireless LAN.

1. Use the [MENU] button to select "WIRELESS LAN," then use "WIRELESS ID" to set the wireless ID.

The device name and SSID change automatically when you make the "WIRELESS ID" setting.

2. Press the [MENU] button to quit the menu.

Checking the Wi-Fi Information

Here you check the Wi-Fi information for the unit.

1. Use the [MENU] button to select "WIRELESS LAN" → "INFORMATION," then press the [VALUE] dial.

The "WLAN INFORMATION" popup appears.

You can check and verify the following information.

| Indication | Description |
|-------------|---|
| STATUS | This displays the connection status. CONNECTED: Connected to the Wi-Fi router. NOT CONNECTED: A wireless USB adaptor is attached, but no connection to the Wi-Fi router is in effect. NOT AVAILABLE: No wireless USB adaptor is attached. AD-HOC: In ad-hoc mode. |
| SSID | This displays the SSID. |
| IP ADDRESS | This displays the IP address. |
| SUBNET MASK | This displays the subnet mask. |
| MAC ADDRESS | This displays the MAC address. |
| AD-HOC KEY | This displays the ad-hoc key. |

2. Press the [MENU] button to quit the menu.

Making a Wired Connection to the Wi-Fi Router

Here you connect the unit to the Wi-Fi router using a network cable and make a wireless connection to the iPad via the router.

* For information on how to operate the Wi-Fi router, refer to the router's documentation.

1. Use a network cable to connect the LAN port on the unit to the Wi-Fi router.
2. Use the [MENU] button to select "LAN" and then make the following settings.

| Menu item | Description |
|------------|---|
| CONFIGURE | This sets whether the IP address is obtained automatically (USING DHCP) or set manually (MANUALLY). |
| IP ADDRESS | This sets the IP address when "CONFIGURE" is set to "MANUALLY." * The subnet mask is fixed at "255.255.255.0" and cannot be changed. |

3. Press the [MENU] button to quit the menu.

4. Connect the iPad and the Wi-Fi router.

- 1 On the iPad, tap "Settings" → "Wi-Fi," make sure Wi-Fi is turned on, then at "Choose a Network," select the Wi-Fi router to which the unit is connected.

Important Notes When Working with Copyright-protected (HDCP) Video

Setting "AUDIO FOLLOW" under "AUDIO INPUT" to "OFF" sends audio to all output channels. When "AUDIO FOLLOW" is set to "OFF," all output channels are affected. Give attention to processing when inputting HDCP-applied video.

When inputting or outputting copyright-protected (HDCP) video, if the following two conditions are both met, the HDCP signal is combined with the audio signals on other channels. This intermixing of the HDCP signal inhibits output of audio on the other channels.

(1) "AUDIO FOLLOW" is set to "OFF"

(2) The send level for audio sent to the output channel is set at 1% or higher.

* To set the send level for the audio for each output channel, at "AUDIO INPUT," select "HDMI-1" to "HDMI-4," then make the setting for "OUT1 SEND RATE" to "OUT4 SEND RATE" (Note: This varies according to the model.).

Example of Settings When No Audio Is Output (Shown in the figure below)

When HDMI-2 input video is output to OUTPUT2 with HDCP = "DISABLE"

When "AUDIO FOLLOW" for HDCP-applied HDMI-3 is set to "OFF" and audio is sent to OUTPUT2 as well, the HDCP signal is combined with the HDMI-2 audio signal, and so the HDMI-2 audio is not output (shown by *1 in the figure below).

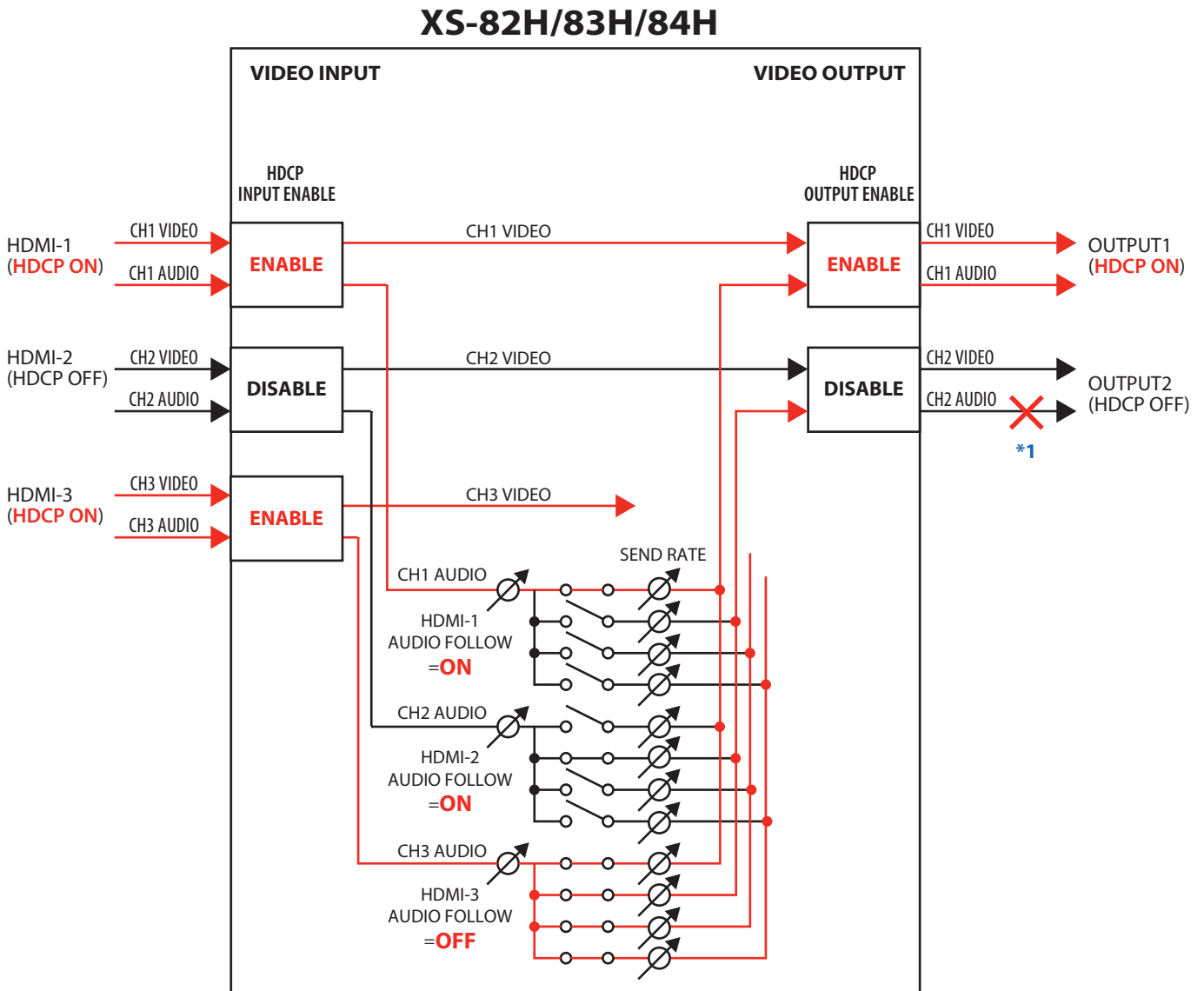

Command Reference

You can use the RS-232C connector and LAN port to operate the unit from an external device.

Specification of the RS-232C Connector

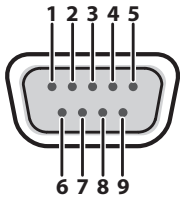

D-sub 9-pin (male)

| Pin No. | Signal |
|---------|--------|
| 1 | N.C. |
| 2 | RXD |
| 3 | TXD |
| 4 | DTR |
| 5 | GND |
| 6 | DSR |
| 7 | RTS |
| 8 | CTS |
| 9 | N.C. |

| | |
|----------------------|---|
| Communication method | Synchronous (asynchronous), full-duplex |
| Communication speed | 9600 bps / 38400 bps |
| Parity | none |
| Data length | 8 bit |
| Stop bit | 1 bit |
| Code set | ASCII |
| Flow control | XON/XOFF |

MEMO

To operate the unit remotely by receiving commands from an external device via the RS-232C connector, press the [MENU] button and select "RS-232C," then set "FUNCTION" to "RECEIVER."

Overview of Commands

The format of commands is an ASCII code string composed of "3 letters (upper case)" plus ";" (semicolon) plus "CR" (0dH).

If the command has an argument, a colon (":") is inserted between the command letters and the argument. When multiple arguments occur, they are separated by commas (",").

":"

This is the code to separate the command and its argument.

";" "CR"

This is the code that the unit recognizes as the end of a command.

- * When using RS-232C, no "CR" is required.
- * The codes of CR (0DH), Xon (11H)/ Xoff (13H) are the control codes.
- * When successively sending commands to the unit from an external device, after each command, be sure that "ACK;" is returned before sending the next command.

Control Using the LAN Port

You can use TCP control commands to operate the unit remotely from an external device.

| | |
|-------------|----------|
| Port | LAN port |
| Protocol | TCP |
| Port number | 8023 |

Making the LAN Settings

1. Use the [MENU] button to select "LAN" and then make the following settings.

| Menu item | Description |
|------------|---|
| CONFIGURE | This sets whether the IP address is obtained automatically (USING DHCP) or set manually (MANUALLY). |
| IP ADDRESS | This sets the IP address when "CONFIGURE" is set to "MANUALLY." * The subnet mask is fixed at "255.255.255.0" and cannot be changed. |

2. Press the [MENU] button to quit the menu.

Verifying the LAN Information

1. Use the [MENU] button to select "LAN" and then "INFORMATION," then press the [VALUE] dial.

The "LAN INFORMATION" popup appears.

You can check and verify the following information.

| Indication | Description |
|-------------|---|
| STATUS | CONNECTED: A LAN cable is connected. NOT CONNECTED: No LAN cable is connected. |
| IP ADDRESS | This displays the IP address. |
| SUBNET MASK | This displays the subnet mask. |
| MAC ADDRESS | This displays the MAC address. |

2. Press the [MENU] button to quit and close the "LAN INFORMATION" popup.

Received Commands

VIS This selects the type for a video input channel.

VIS:a,b;

a: Input channel number 0 (CH 1)–7 (CH 8)

b: Input type

0: HDMI, 1: RGB/COMPONENT, 2: COMPOSITE, 3: YC,
4: STILL1, 5: STILL2, 6: STILL3, 7: STILL4, 8: SHARE

VIC This selects the color space for a video input channel.

VIC:a,b;

a: Input channel number 0 (CH 1)–7 (CH 8)

b: Color space

0: Auto, 1: RGB (0–255), 2: RGB (16–235), 3: YCC (SD), 4: YCC (HD)

VIH This sets HDCP for a video input channel.

VIH:a,b;

a: Input channel number 0 (CH 1)–7 (CH 8)

b: HDCP Input Enable 0: Disable, 1: Enable

VIA This sets the aspect ratio for a video input channel.

VIA:a,b;

a: Input channel number 0 (CH 1)–7 (CH 8)

b: Aspect ratio

0: Full, 1: Letterbox, 2: Crop, 3: Dot by Dot, 4: Manual

VOS This makes the OUTPUT SELECT setting for a video output channel.

VOS:a,b;

a: Output channel number 0 (CH 1)–3 (CH 4)

b: OUTPUT SELECT 0: Auto, 1: HDMI, 2: HDBaseT

VOR This sets the video output resolution.

VOR:a,b;

a: Output channel number 0 (CH 1)–3 (CH 4)

b: OUTPUT RESOLUTION

0: 480i 4:3/576i 4:3, 1: 480i 16:9/576i 16:9, 2: 480p 4:3/576p 4:3,
3: 480p 16:9/576p 16:9, 4: 720/59.94P, 5: 1080/59.94i, 6: 1080/59.94P,
7: 640 x 480, 8: 800 x 600, 9: 1024 x 768, 10: 1280 x 768, 11: 1366 x 768,
12: 1280 x 1024, 14: 1600 x 1200, 15: 1920 x 1200

VOH This sets HDCP for a video output channel.

VOH:a,b;

a: Output channel number 0 (CH 1)–3 (CH 4)

b: HDCP Output Enable 0: Disable, 1: Enable

VOC This selects the color space for a video output channel.

VOC:a,b;

a: Output channel number 0 (CH 1)–3 (CH 4)

b: Color space

0: Auto, 1: RGB (0–255), 2: RGB (16–235), 3: YCC (444), 4: YCC (422)

VOD This sets the signal type for a video output channel.

VOD:a,b;

a: Output channel number 0 (CH 1)–3 (CH 4)

b: DVI-D/HDMI Signal 0: DVI-D, 1: HDMI

OAV This selects the input channel for video and audio sent to OUTPUT.

OAV:a,b;

a: Output channel number 0 (CH 1)–3 (CH 4)

b: Input channel number 0 (CH 1)–7 (CH 8)

OVS This selects the input channel for video sent to OUTPUT.

OVS:a,b;

a: Output channel number 0 (CH 1)–3 (CH 4)

b: Input channel number 0 (CH 1)–7 (CH 8)

OAS This selects the input channel for audio sent to OUTPUT.

OAS:a,b;

a: Output channel number 0 (CH 1)–3 (CH 4)

b: Input channel number 0 (CH 1)–7 (CH 8)

OFS This changes the state of the [OFF] button.

OFS:a,b;

a: Output channel number 0 (CH 1)–3 (CH 4)

b: [OFF] button 0: Off, 1: On

IDL This sets the level of audio input via the HDMI INPUT connectors.

IDL:a,b;

a: Input channel number 0 (CH 1)–7 (CH 8)

b: Level 0–127

IAL This sets the level of audio input via the AUDIO INPUT connectors.

IAL:a,b;

a: Input channel number 0 (CH 1)–7 (CH 8)

b: Level 0–127

OAL This sets the output level for audio.

OAL:a,b;

a: Output channel number 0 (CH 1)–3 (CH 4)

b: Level 0–127

IDM This sets muting on or off of audio input via the HDMI INPUT connectors.

IDM:a,b;

a: Input channel number 0 (CH 1)–7 (CH 8)

b: Mute 0: Off, 1: On

IAM This sets muting on or off of audio input via the AUDIO INPUT connectors.

IAM:a,b;

a: Input channel number 0 (CH 1)–7 (CH 8)

b: Mute 0: Off, 1: On

OAM This sets muting on or off for output audio.

OAM:a,b;

a: Output channel number 0 (CH 1)–3 (CH 4)

b: Mute 0: Off, 1: On

Command Reference

ADT This sets the delay time for output audio.

ADT:a,b;

- a: Output channel number 0 (CH 1)–3 (CH 4)
- b: Level 0–170 (ms)

MOD This sets the video output mode.

MOD:a;

- a: Mode type
- 0: MATRIX, 1: MULTI-2, 2: MULTI-3, 3: MULTI-4, 4: SPAN-2, 5: SPAN-3, 6: SPAN-4, 7: ROTATION-L1, 8: ROTATION-L2, 9: ROTATION-L3, 10: ROTATION-L4, 11: ROTATION-R1, 12: ROTATION-R2, 13: ROTATION-R3, 14: ROTATION-R4, 15: 4K-1, 16: 4K-2, 17: DISSOLVE-1, 18: PGM-PST

PSE This calls up settings saved at a preset.

PSE:a;

- a: Preset number 0 (1)–31 (32)

ITS This returns the state of INPUT.

ITS:a;

- a: Input channel number 0 (CH 1)–7 (CH 8)

OTS This returns the state of OUTPUT.

OTS:a;

- a: Output channel number 0 (CH 1)–3 (CH 4)

CTS This returns the state of the cross-point selection buttons.

CTS:a;

- a: Output channel number 0 (CH 1)–3 (CH 4)

ATO When in the PGM-PST mode, this executes an auto take.

ATO:a,b;

- a: Output channel number 0 (CH 1)
- b: TAKE SW1: AUTO TAKE

ASA This sets the send level for audio sent to OUTPUT1.

ASA:a,b;

- a: Input channel number
0 (HDMI-IN1)–7 (HDMI-IN8), 8 (ANALOG-IN1)–15 (ANALOG-IN8)
- b: Send Rate 0–100 (%)

ASB This sets the send level for audio sent to OUTPUT2.

ASB:a,b;

- a: Input channel number
0 (HDMI-IN1)–7 (HDMI-IN8), 8 (ANALOG-IN1)–15 (ANALOG-IN8)
- b: Send Rate 0–100 (%)

ASC This sets the send level for audio sent to OUTPUT3.

ASC:a,b;

- a: Input channel number
0 (HDMI-IN1)–7 (HDMI-IN8), 8 (ANALOG-IN1)–15 (ANALOG-IN8)
- b: Send Rate 0–100 (%)

ASD This sets the send level for audio sent to OUTPUT4.

ASD:a,b;

- a: Input channel number
0 (HDMI-IN1)–7 (HDMI-IN8), 8 (ANALOG-IN1)–15 (ANALOG-IN8)
- b: Send Rate 0–100 (%)

PLS This sets panel lock on or off.

PLS:a;

- a: Panel Lock Sw 0: Off, 1: On
- * When the parameters for “KEY LOCK MODE” under “SYSTEM” are all set to “OFF,” panel lock is not set on when “On” is sent.

KLM This sets the key lock mode.

KLM:a,b;

- a: Key Lock Mode
0: CROSSPOINT, 1: SWITCHING MODE, 2: MENU+EXIT, 3: CURSOR+VALUE, 4: CROSS-NOINPUT, 5: CROSS-OFF, 6: CROSS-OUTPUT1, 7: CROSS-OUTPUT2, 8: CROSS-OUTPUT3, 9: CROSS-OUTPUT4
- b: Key Lock Sw 0: Off, 1: On

KLS This returns the state of the key lock mode.

KLS;

VER This returns version information.

VER;

ACS This verifies the status of the unit. While in operation, “ACK;” is returned.

ACS;

XON This is flow control.

XON

XOFF This is flow control.

XOFF

Sent Commands

ACK This is sent when a transmitted command has been correctly received.

ACK;

ERR This is sent when a transmitted command has not been correctly received.

ERR:a;

- a: 0 (syntax error): The received command contains an error.
- 4 (invalid value error): An argument of the received command is invalid.
- 5 (out of range error): An argument of the received command is out of range.

ITS This verifies the state of a video input channel.

ITS:a,b,c,d,e;

- a: Input channel number 0 (CH 1)–7 (CH 8)
- b: Input type
 - 0: HDMI, 1: RGB/COMPONENT, 2: COMPOSITE, 3: YC, 4: STILL1, 5: STILL2, 6: STILL3, 7: STILL4, 8: SHARE
- c: Color space
 - 0: Auto, 1: RGB (0–255), 2: RGB (16–235), 3: YCC (SD), 4: YCC (HD)
- d: HDCP Input Enable 0: Disable, 1: Enable
- e: Aspect ratio
 - 0: Full, 1: Letterbox, 2: Crop, 3: Dot by Dot, 4: Manual

OTS This verifies the state of a video output channel.

OTS:a,b,c,d,e,f;

- a: Output channel number 0 (CH 1)–3 (CH 4)
- b: OUTPUT SELECT 0: Auto, 1: HDMI, 2: HDBaseT
- c: OUTPUT RESOLUTION
 - 0: 480i 4:3/576i 4:3, 1: 480i 16:9/576i 16:9,
 - 2: 480p 4:3/576p 4:3, 3: 480p 16:9/576p 16:9,
 - 4: 720/59.94P, 5: 1080/59.94i, 6: 1080/59.94P, 7: 640 x 480,
 - 8: 800 x 600, 9: 1024 x 768, 10: 1280 x 768,
 - 11: 1366 x 768, 12: 1280 x 1024, 14: 1600 x 1200, 15: 1920 x 1200
- d: HDCP Output Enable 0: Disable, 1: Enable
- e: Color space
 - 0: Auto, 1: RGB (0–255), 2: RGB (16–235), 3: YCC (444), 4: YCC (422)
- f: DVI-D/HDMI Signal 0: DVI-D, 1: HDMI

CTS This verifies the state of the cross-point selection buttons.

CTS:a,b,c,d;

- a: Output channel number 0 (CH 1)–3 (CH 4)
- b: Video selection channel number 0 (CH 1)–7 (CH 8)
- c: Audio selection channel number 0 (CH 1)–7 (CH 8)
- d: OUTPUT [OFF] button status 0: Off, 1: On

KLS This verifies the state of the key lock mode.

KLS:a,b,c,d,e,f,g,h,i,j,k;

- a: Lock Status 0: Off, 1: On
- b: Cross Point 0: Off, 1: On
- c: Switch Mode 0: Off, 1: On
- d: Menu+Exit 0: Off, 1: On
- e: Cursor+Value 0: Off, 1: On
- e: Cursor+Value 0: Off, 1: On
- f: Cross-Noinput 0: Off, 1: On
- g: Cross-Off 0: Off, 1: On
- h: Cross-Output1 0: Off, 1: On
- i: Cross-Output2 0: Off, 1: On
- j: Cross-Output3 0: Off, 1: On
- k: Cross-Output4 0: Off, 1: On

VER This is sent when a VER command has been received.

VER:XS-8aH,b;

- a: XS-82H=2, XS-83H=3, XS-84H=4
- b: Version *The version info is ASCII text strings.

XON This is flow control.

XON

XOFF This is flow control.

XOFF

